



**BREDE VALLEY**  
MUNICIPALITY • MUNISIPALITEIT • UMASIPALA

30 Baring Street, Worcester, Western Cape,  
South Africa, 6849, Private Bag X3046

A caring valley of excellence.



Date: 13.01.2022		Closing Date: 24.01.2022		Time: 11:00 AM	
Enquiries :	<b>SCM RELATED</b> <b>Ms M. Mphatsoane</b> Phone +27 (0) 23 348 2953 e-mail mimi@bvm.gov.za	<b>TECHNICAL SPECIFICATIONS</b> <b>H SCHREUDER</b> hschreuder@bvm.gov.za		E – MAIL: <b>evaluations@bvm.gov.za</b> FAX 2 MAIL: <b>086 560 7956</b>	
Name of Company:				Quotation Reference: <b>318122</b>	
Item:	Description:			<b>Total carried over from Schedule of Quantities (SUMMARY SECTION)</b>	
<b>1</b>	<b>MAINTENANCE OF 66-11KV TRANSFORMERS AS PER DETAILED SPECIFICATION.</b>				
			Subtotal:		
VAT Registered? Yes/No			Included? Yes/No		VAT @ 15%
VAT Number:				Total:	
Period of Performance as required by the client (municipality):	Within 40 working days, from date of official order.				
Completion Period as indicated by the supplier	Within _____ working days, from date of official order.				
Delivery Address: <b>BREDE VALLEY MUNICIPALITY, ELECTRICITY DEPARTMENT</b>					
Specification Enquiries: <b>H SCHREUDER hschreuder@bvm.gov.za</b>					
<u>Compulsory Site Inspection/Meeting:</u> <u>ELECTRICITY DEPARTMENT</u> <u>WORCESTER behind Fire Brigade</u>		Date: <b>19.01.2022</b>		Time: <b>09:00</b>	
Authorised Signature:			Official Stamp:		
Print Name:					
Date:					

## SCHEDULE 1- INVITATION TO QUOTE

Breede Valley Municipality invites quotations from suitably qualified service providers for: **QUOTE REFERENCE NUMBER: 318122:**

### **MAINTENANCE OF 66-11kV TRANSFORMERS AS PER DETAILED SPECIFICATION.**

A set of Quotation Documents can be obtained from the Breede Valley Municipality, Supply Chain Management Unit's Offices, 51b Baring Street, Worcester. Alternatively, Quotation Documents can be downloaded from the municipal website.

Any enquiries regarding technical information shall be directed to Mr Heinrich Schreuder at [hschreuder@bvm.gov.za](mailto:hschreuder@bvm.gov.za)

Completed offers, in properly sealed envelopes and clearly marked on the outside with the corresponding quotation number and description, must timeously be submitted on or before the closing date and time in either one of the following ways

- (1) To be placed in the municipality's tender box situated at the Revenue section, 53 Baring Street, Worcester, or
- (2) By fax at: **086 560 7956**, or
- (3) By e-mail at: [evaluations@bvm.gov.za](mailto:evaluations@bvm.gov.za)

***The closing date and time of this quotation is: 11h00 on Monday, 24.01.2022 If the quotation is submitted late, it shall not be accepted for consideration.***

## REQUEST FOR WRITTEN QUOTATION

REF NR: 318122

TO:

FAXED TO NO.:

In terms of paragraph 16 and 17 of the Municipal Supply Chain Management Policy, you are hereby invited to quote for the goods and or services as contained in the attached request to quote form and, in addition to the general conditions of contract, as per the following special conditions:

### CONDITIONS OF QUOTE:

1. This quotation consists of two parts, which are Part A (Returnable Schedules) and Part B (Contract Details and Pricing Schedule). All the schedules of Part A, as well as the pricing schedule, must be completed.
2. Quotes MUST be submitted before the closing date and time as indicated in the request to quote form attached;
3. Quotes MUST be completed and submitted on the attached request to quote form;
4. Quotes MUST be for the product or service as specified. If alternate products is quoted for, it MUST be of the same quality and equivalent to the product specified. Full details of alternate products MUST be supplied. Non-compliance to this condition will invalidate your quote;
5. Delivery charges MUST be specified, where applicable. If not specified, it will be regarded as included in the quoted amount;
6. Amount(s) quoted MUST remain valid for at least thirty (30) days from the specified closing date;
7. Amount(s) quoted MUST be firm and must be inclusive of VAT. If the supplier is NOT registered for VAT, no VAT may be claimed;
8. Calculation errors will be corrected, tariffs will be regarded as correct where the bid is based on quantities. The corrected prices shall be used for the purposes of evaluating quotations.
9. A firm delivery period MUST be indicated;
10. Quotes MUST be duly signed by an authorised person;
11. An original and valid Tax Clearance Certificate MUST be submitted, and No tender may be awarded to any person whose tax matters have not been declared by the South African Revenue Service to be in order.
12. A certificate stating that neither the enterprise or its Director(s) or Member(s) or Owners' municipal account(s) are in arrears for longer than three (3) months;
13. The municipality may accept the whole or a part of the bid (offer) where the bid request comprises of more than one item;
14. The municipality does not bind itself to accept the lowest or any bid;
15. Quotes received shall be evaluated on a comparative basis in terms of the 80/20 preference point system as prescribed in the Preferential Procurement Policy Framework Act, 2000 (Act no 5 of 2000); Amended by Government Gazette 8 June 2011 (no 34350)
16. The successful provider will be the provider scoring the highest points;
17. The acceptance of the quote and the subsequent issuing of an official order constitute a legal binding document and may not be cancelled;
18. Goods or Services may only be provided after and according to the issued official order;
19. Payment will only be made after the goods is delivered and or service is rendered, to the satisfaction of the Municipality, as per official order; and
20. Payment will only be made within thirty (30) days of receipt of monthly statement and the relevant VAT invoice containing the official order number and the municipalities' VAT number.

Failure to comply with any of these conditions may invalidate your quote.

Yours sincerely

**M. Potgieter**

Head: Supply Chain Management

SKAKEL ASSEMBLIEF AS ONDUIDELIK OF AS KORREKTE AANTAL BLADSYE NIE ONTVANG IS NIE

**PART A: RETURNABLE SCHEDULES**

**Contents**

---

Schedule 01: Authority for Signatory

Schedule 02: Declaration in terms of the MFMA<sup>1</sup>

Schedule 03: Tax Clearance Certificate

Schedule 04: Preference Points

Schedule 05: Proof of Payment of Municipal Rates and Taxes

Schedule 06: Declaration Certificate for local production and content MBD 6.2

Schedule 07: Declaration of Bidders past Supply Chain Management Practices MBD 8

Schedule 08: MBD 9

---

<sup>1</sup> Municipal Finance Management Act, 2003 (Act No. 56 of 2003)

## INVITATION TO BID

<b>YOU ARE HEREBY INVITED TO BID FOR REQUIREMENTS OF THE (NAME OF MUNICIPALITY/ MUNICIPAL ENTITY)</b>					
BID NUMBER:	318122	CLOSING DATE:	24.01.2022	CLOSING TIME:	11:00 AM
<b>DESCRIPTION</b>					
<b>MAINTENANCE OF 66-11kV TRANSFORMERS AS PER DETAILED SPECIFICATION.</b>					
<b>THE SUCCESSFUL BIDDER WILL BE REQUIRED TO FILL IN AND SIGN A WRITTEN CONTRACT FORM (MBD7).</b>					

<b>51b Baring Street, Worcester</b>					
<b>SUPPLIER INFORMATION</b>					
NAME OF BIDDER					
POSTAL ADDRESS					
STREET ADDRESS					
TELEPHONE NUMBER	CODE		NUMBER		
CELLPHONE NUMBER					
FACSIMILE NUMBER	CODE		NUMBER		
E-MAIL ADDRESS					
VAT REGISTRATION NUMBER					
TAX COMPLIANCE STATUS	TCS PIN:		OR	CSD No:	
B-BBEE STATUS LEVEL VERIFICATION CERTIFICATE [TICK APPLICABLE BOX]	<input type="checkbox"/> Yes  <input type="checkbox"/> No		B-BBEE STATUS LEVEL SWORN AFFIDAVIT	<input type="checkbox"/> Yes  <input type="checkbox"/> No	
<b>[A B-BBEE STATUS LEVEL VERIFICATION CERTIFICATE/ SWORN AFFIDAVIT (FOR EMES &amp; QSEs) MUST BE SUBMITTED IN ORDER TO QUALIFY FOR PREFERENCE POINTS FOR B-BBEE]</b>					
(a) ARE YOU THE ACCREDITED REPRESENTATIVE IN SOUTH AFRICA FOR THE GOODS /SERVICES /WORKS OFFERED?	<input type="checkbox"/> Yes <input type="checkbox"/> No [IF YES ENCLOSE PROOF]		(b) ARE YOU A FOREIGN BASED SUPPLIER FOR THE GOODS /SERVICES /WORKS OFFERED?	<input type="checkbox"/> Yes <input type="checkbox"/> No [IF YES, ANSWER PART B:3]	
(c) TOTAL NUMBER OF ITEMS OFFERED			(d) TOTAL BID PRICE	<b>R</b>	
(e) SIGNATURE OF BIDDER	.....		(f) DATE		

(g) CAPACITY UNDER WHICH THIS BID IS SIGNED			
<b>BIDDING PROCEDURE ENQUIRIES MAY BE DIRECTED TO:</b>		<b>TECHNICAL INFORMATION MAY BE DIRECTED TO:</b>	
DEPARTMENT	<b>SUPPLY CHAIN</b>	CONTACT PERSON	<b>MR. H Schreuder</b>
CONTACT PERSON	<b>Ms. M. Mphatsoane</b>	TELEPHONE NUMBER	
TELEPHONE NUMBER	<b>023 348 2953</b>	FACSIMILE NUMBER	
FACSIMILE NUMBER	<b>086 560 7956</b>	E-MAIL ADDRESS	<b>hschreuder@bvm.gov.za</b>
E-MAIL ADDRESS			

## PART B TERMS AND CONDITIONS FOR BIDDING

<b>1. BID SUBMISSION:</b>	
1.1.	BIDS MUST BE DELIVERED BY THE STIPULATED TIME TO THE CORRECT ADDRESS. LATE BIDS WILL NOT BE ACCEPTED FOR CONSIDERATION.
1.2.	<b>ALL BIDS MUST BE SUBMITTED ON THE OFFICIAL FORMS PROVIDED-(NOT TO BE RE-TYPED) OR ONLINE</b>
1.3.	THIS BID IS SUBJECT TO THE PREFERENTIAL PROCUREMENT POLICY FRAMEWORK ACT AND THE PREFERENTIAL PROCUREMENT REGULATIONS, 2017, THE GENERAL CONDITIONS OF CONTRACT (GCC) AND, IF APPLICABLE, ANY OTHER SPECIAL CONDITIONS OF CONTRACT.
<b>2. TAX COMPLIANCE REQUIREMENTS</b>	
2.1	BIDDERS MUST ENSURE COMPLIANCE WITH THEIR TAX OBLIGATIONS.
2.2	BIDDERS ARE REQUIRED TO SUBMIT THEIR UNIQUE PERSONAL IDENTIFICATION NUMBER (PIN) ISSUED BY SARS TO ENABLE THE ORGAN OF STATE TO VIEW THE TAXPAYER'S PROFILE AND TAX STATUS.
2.3	APPLICATION FOR THE TAX COMPLIANCE STATUS (TCS) CERTIFICATE OR PIN MAY ALSO BE MADE VIA E-FILING. IN ORDER TO USE THIS PROVISION, TAXPAYERS WILL NEED TO REGISTER WITH SARS AS E-FILERS THROUGH THE WEBSITE WWW.SARS.GOV.ZA.
2.4	FOREIGN SUPPLIERS MUST COMPLETE THE PRE-AWARD QUESTIONNAIRE IN PART B:3.
2.5	BIDDERS MAY ALSO SUBMIT A PRINTED TCS CERTIFICATE TOGETHER WITH THE BID.
2.6	IN BIDS WHERE CONSORTIA / JOINT VENTURES / SUB-CONTRACTORS ARE INVOLVED, EACH PARTY MUST SUBMIT A SEPARATE TCS CERTIFICATE / PIN / CSD NUMBER.
2.7	WHERE NO TCS IS AVAILABLE BUT THE BIDDER IS REGISTERED ON THE CENTRAL SUPPLIER DATABASE (CSD), A CSD NUMBER MUST BE PROVIDED.
<b>3. QUESTIONNAIRE TO BIDDING FOREIGN SUPPLIERS</b>	
3.1.	IS THE ENTITY A RESIDENT OF THE REPUBLIC OF SOUTH AFRICA (RSA)? <span style="float: right;"><input type="checkbox"/> YES <input type="checkbox"/> NO</span>
3.2.	DOES THE ENTITY HAVE A BRANCH IN THE RSA? <span style="float: right;"><input type="checkbox"/> YES <input type="checkbox"/> NO</span>
3.3.	DOES THE ENTITY HAVE A PERMANENT ESTABLISHMENT IN THE RSA? <span style="float: right;"><input type="checkbox"/> YES <input type="checkbox"/> NO</span>
3.4.	DOES THE ENTITY HAVE ANY SOURCE OF INCOME IN THE RSA? <span style="float: right;"><input type="checkbox"/> YES <input type="checkbox"/> NO</span>
3.5.	IS THE ENTITY LIABLE IN THE RSA FOR ANY FORM OF TAXATION? <span style="float: right;"><input type="checkbox"/> YES <input type="checkbox"/> NO</span>
<b>IF THE ANSWER IS "NO" TO ALL OF THE ABOVE, THEN IT IS NOT A REQUIREMENT TO REGISTER FOR A TAX COMPLIANCE STATUS SYSTEM PIN CODE FROM THE SOUTH AFRICAN REVENUE SERVICE (SARS) AND IF NOT REGISTER AS PER 2.3 ABOVE.</b>	

**NB: FAILURE TO PROVIDE ANY OF THE ABOVE PARTICULARS MAY RENDER THE BID INVALID.  
NO BIDS WILL BE CONSIDERED FROM PERSONS IN THE SERVICE OF THE STATE.**

SIGNATURE OF BIDDER: .....

CAPACITY UNDER WHICH THIS BID IS SIGNED: .....

DATE: .....

SCHEDULE 1  
AUTHORITY FOR SIGNATORY

**I, the undersigned, warrant that I am duly authorised to do complete this quotation on behalf of the enterprise.**

Registered Name of Enterprise: \_\_\_\_\_

Trading Name of Enterprise: \_\_\_\_\_

ADDRESS: POSTAL: \_\_\_\_\_ STREET: \_\_\_\_\_

\_\_\_\_\_

Postal Code: \_\_\_\_\_

TELEPHONE: CODE & NUMBER \_\_\_\_\_ FACSIMILE: CODE & NUMBER \_\_\_\_\_

CELL PHONE NUMBER \_\_\_\_\_ E-MAIL ADDRESS: \_\_\_\_\_

CORRESPONDENCE METHOD

PLEASE SELECT YOUR PREFERRED METHOD OF CORRESPONDENCE. ALL CORRESPONDENCE WILL BE SEND USING THE METHOD YOU SELECT BELOW.

EXPLANATION OF ABBREVIATIONS USED IN THE FOLLOWING TABLE

Capacity		
FAX	F	
E-MAIL	E	
POSTAL	P	

LANGUAGE PREFERENCE: \_\_\_\_\_

TAX REFERENCE NUMBER: \_\_\_\_\_ VAT REGISTRATION NUMBER (if any): \_\_\_\_\_

CIDB<sup>2</sup> REGISTRATION NUMBER (if any): \_\_\_\_\_ GRADING: \_\_\_\_\_

**(Certified copy of registration document must be attached)**

REGISTRATION NUMBER: COMPANY / CLOSE CORPORATION / TRUST: \_\_\_\_\_ (delete if not applicable)

**(Certified copy of registration document must be attached)**

SIGNATURE OF THE **AUTHORISED PERSON** \_\_\_\_\_ DATE: \_\_\_\_\_

CAPACITY UNDER WHICH THIS QUOTATION IS SIGNED \_\_\_\_\_

PRINT NAME: \_\_\_\_\_

IDENTITY NUMBER: \_\_\_\_\_

ADDRESS:

Physical: \_\_\_\_\_ Postal: \_\_\_\_\_

\_\_\_\_\_

Code: \_\_\_\_\_

E-MAIL ADDRESS: \_\_\_\_\_

CONTACT NUMBER: TEL. No. \_\_\_\_\_ CELL No. \_\_\_\_\_ FAX No. \_\_\_\_\_

<sup>2</sup> Construction Industry Development Board.



**SCHEDULE 2**

**DECLARATION IN TERMS OF CLAUSE 112(1) OF THE MUNICIPAL FINANCE MANAGEMENT ACT,  
NO. 56 OF 2003. (Section 3)**

The Bidder shall duly complete undermentioned. An authorized person shall duly undersign in this regard. **Failure to duly complete this statement shall subject the quote to rejection.**

**CERTIFICATE in terms of SECTION 112(1) of the MUNICIPAL FINANCE MANAGEMENT ACT 2003 (Act No. 56 of 2003) and  
in terms of CLAUSES 44 and 45 of the MUNICIPAL SUPPLY CHAIN MANAGEMENT POLICY**

I, the undersigned, warrants that I am duly authorised to act on behalf of the enterprise mentioned below and do hereby certify that, to the best of my personal knowledge, neither the enterprise nor any of its owners, directors, members or partners has—

- i) failed to pay any municipal rates and taxes or municipal service charges;
- ii) been in arrears with any municipal accounts with any municipality or municipal entity in the Republic of South Africa, for a period longer than 3 (three) months;
- iii) been convicted of fraud or corruption during the past 5 (five) years;
- iv) abused the supply chain management system of the Municipality or has committed any improper conduct in relation to this system;
- v) failed, during the past 5 (five) years, to perform satisfactory on a previous contract with the Municipality or any other organ of state after written notice was given to the enterprise that performance was unsatisfactory;
- vi) wilfully neglected, reneged on or failed to comply with any government, municipal or other public sector contract during the past 5 (five) years;
- vii) been listed with the Register of Tender Defaulters in terms of section 29 of the Prevention and Combating of Corrupt Activities Act 2004 (Act no. 12 of 2004);
- viii) been listed on National Treasury's database as a person or enterprise prohibited from doing business with the public sector;
- ix) any tax matters that is not cleared by the South African Revenue Services;
- x) been in the service of the state for the past 12 (twelve) months or is in the service of the state; or
- xi) been or is an advisor or consultant contracted with the Municipality.

Further to the above I, the undersigned, herewith disclose the particulars of any kinship (parent, brother, sister or child) with a person that is in the service of the state (see footnote<sup>3</sup>), or has been in the service of the state in the previous twelve months of any of its owners, directors, members or partners:

Full Name of that person:

Kinship/Relationship

Identity Number of that person(s):

Particulars of Employer:

Capacity in which that person is in the service of the state:

<sup>3</sup> MSCM Regulations: "in the service of the state" means to be –

- (a) a member of any municipal council; any provincial legislature; or the national Assembly or the national Council of provinces;
- (b) a member of the board of directors of any municipal entity;
- (c) an official of any municipality or municipal entity;
- (d) an employee of any national or provincial department, national or provincial public entity or constitutional institution within the meaning of the Public Finance Management Act, 1999 (Act No.1 of 1999);
- (e) a member of the accounting authority of any national or provincial public entity; or
- (f) an employee of Parliament or a provincial legislature.

**SCHEDULE 03: VALID AND ORIGINAL TAX CLEARANCE CERTIFICATE—**

Where the bidder has got a reason to believe that he or she has updated his or her database affairs with the municipality or Centralised Supplier Database, the bidder may choose not to attach the updated Tax Clearance Certificate. Otherwise, bidders must attach to this quotation, a **valid** and **original** tax clearance certificate.

**SCHEDULE 04: PREFERENCE POINTS**

Please attach certified BEE certificate to quotes above R30,000

<b>B-BBEE Status Level of Contributor</b>	<b>Number of points (80/20 system)</b>
1	20
2	18
3	14
4	12
5	8
6	6
7	4
8	2
Non-compliant contributor	0

**SCHEDULE 05: PROOF OF PAYMENT OF MUNICIPAL RATES AND TAXES—**

The Bidder must attach to this application a certificate from his / her municipality indicating that all rates and taxes are fully paid or not in arrears for more than three (3) months. Please note that the Municipality reserves it's right to have the account checked before any business is awarded. (Copy of latest Municipal Account(s) or Affidavit confirming of residential address or renting of business premises or Rental Agreement.)

## SCHEDULE 06

### DECLARATION CERTIFICATE FOR LOCAL PRODUCTION AND CONTENT - MBD 6.2

This Municipal Bidding Document (MBD) must form part of all bids invited. It contains general information and serves as a declaration form for local content (local production and local content are used interchangeably).

Before completing this declaration, bidders must study the General Conditions, Definitions, Directives applicable in respect of Local Content as prescribed in the Preferential Procurement Regulations, 2017 and the South African Bureau of Standards (SABS) approved technical specification number SATS 1286:201x.

#### 1. General Conditions

- 1.1. Preferential Procurement Regulations, 2017 (Regulation 8 (1) and 8(2) make provision for the promotion of local production and content.
- 1.2. Regulation 8(1) prescribes that in the case of designated sectors, where in the award of bids local production and content is of critical importance, such bids must be advertised with the specific bidding condition that only locally produced goods, services or works or locally manufactured goods, with a stipulated minimum threshold for local production and content will be considered.
- 1.3. Regulation 8(2) prescribes that where there is no designated sector, a specific bidding condition may be included, that only locally produced services, works or goods or locally manufactured goods with a stipulated minimum threshold for local production and content, will be considered.
- 1.4. Where necessary, for bids referred to in paragraphs 1.2 and 1.3 above, a two-stage bidding process may be followed, where the first stage involves a minimum threshold for local production and content and the second stage price and B-BBEE.
- 1.5. A person awarded a contract in relation to a designated sector, may not sub-contract in such a manner that the local production and content of the overall value of the contract is reduced to below the stipulated minimum threshold.
- 1.6. The local content (LC) as a percentage of the bid price must be calculated in accordance with the SABS approved technical specification number SATS 1286: 201x as follows:

$$LC = \left(1 - \frac{x}{y}\right) \times 100$$

Where

x imported content

y bid price excluding value added tax (VAT)

Prices referred to in the determination of x must be converted to Rand (ZAR) by using the exchange rate published by the South African Reserve Bank (SARB) at 12:00 on the date, one week (7 calendar days) prior to the closing date of the bid as required in paragraph 4.1 below.

#### 1.7. A bid will be disqualified if:

- the bidder fails to achieve the stipulated minimum threshold for local production and content indicated in paragraph 3 below; and
- this declaration certificate is not submitted as part of the bid documentation.

#### 2. Definitions

- 2.1. “**bid**” includes advertised competitive bids, written price quotations or proposals;

- 2.2. **“bid price”** price offered by the bidder, excluding value added tax (VAT);
- 2.3. **“contract”** means the agreement that results from the acceptance of a bid by an organ of state;
- 2.4. **“designated sector”** means a sector, sub-sector or industry that has been designated by the Department of Trade and Industry in line with national development and industrial policies for local production, where only locally produced services, works or goods or locally manufactured goods meet the stipulated minimum threshold for local production and content;
- 2.5. **“duly sign”** means a Declaration Certificate for Local Content that has been signed by the Chief Financial Officer or other legally responsible person nominated in writing by the Chief Executive, or senior member / person with management responsibility (close corporation, partnership or individual).
- 2.6. **“imported content”** means that portion of the bid price represented by the cost of components, parts or materials which have been or are still to be imported (whether by the supplier or its subcontractors) and which costs are inclusive of the costs abroad, plus freight and other direct importation costs, such as landing costs, dock duties, import duty, sales duty or other similar tax or duty at the South African port of entry;
- 2.7. **“local content”** means that portion of the bid price, which is not included in the imported content, provided that local manufacture does take place;
- 2.8. **“stipulated minimum threshold”** means that portion of local production and content as determined by the Department of Trade and Industry; and
- 2.9. **“sub-contract”** means the primary contractor’s assigning, leasing, making out work to, or employing another person to support such primary contractor in the execution of part of a project in terms of the contract.

**3. The stipulated minimum threshold(s) for local production and content for this bid is/are as follows:**

<u>Description of services, works or goods</u>	<u>Stipulated minimum threshold</u>
_____	_____ %
_____	_____ %
_____	_____ %

4. Does any portion of the services, works or goods offered have any imported content? YES / NO
- 4.1 If yes, the rate(s) of exchange to be used in this bid to calculate the local content as prescribed in paragraph 1.6 of the general conditions must be the rate(s) published by the SARB for the specific currency at 12:00 on the date, one week (7 calendar days) prior to the closing date of the bid.

The relevant rates of exchange information is accessible on [www.reservebank.co.za](http://www.reservebank.co.za). Indicate the rate (s) of exchange against the appropriate currency in the table below:

<b>Currency</b>	<b>Rates of exchange</b>
US Dollar	
Pound Sterling	
Euro	
Yen	
Other	

**NB: Bidders must submit proof of the SARB rate (s) of exchange used.**

**LOCAL CONTENT DECLARATION BY CHIEF FINANCIAL OFFICER OR OTHER LEGALLY RESPONSIBLE PERSON NOMINATED  
IN WRITING BY THE CHIEF EXECUTIVE OR SENIOR MEMBER/PERSON WITH MANAGEMENT RESPONSIBILITY (CLOSE  
CORPORATION, PARTNERSHIP OR INDIVIDUAL)**

**IN RESPECT OF BID No.** .....

**ISSUED BY:** (Procurement Authority / Name of Municipality / Municipal Entity):  
.....

NB The obligation to complete, duly sign and submit this declaration cannot be transferred to an external authorized representative, auditor or any other third party acting on behalf of the bidder.

I, the undersigned, ..... (full names),  
do hereby declare, in my capacity as .....  
of .....(name of bidder entity), the following:

- (a) The facts contained herein are within my own personal knowledge.
- (b) I have satisfied myself that the goods/services/works to be delivered in terms of the above-specified bid comply with the minimum local content requirements as specified in the bid, and as measured in terms of SATS 1286.
- (c) The local content has been calculated using the formula given in clause 3 of SATS 1286, the rates of exchange indicated in paragraph 4.1 above and the following figures:

Bid price, excluding VAT (y)	R
Imported content (x)	R
Stipulated minimum threshold for Local content (paragraph 3 above)	
Local content % as calculated in terms of SATS 1286	

If the bid is for more than one product, a schedule of the local content by product shall be attached.

(d) I accept that the Procurement Authority / Municipality /Municipal Entity has the right to request that the local content be verified in terms of the requirements of SATS 1286.

(e) I understand that the awarding of the bid is dependent on the accuracy of the information furnished in this application. I also understand that the submission of incorrect data, or data that are not verifiable as described in SATS 1286, may result in the Procurement Authority / Municipal / Municipal Entity imposing any or all of the remedies as provided for in Regulation 14 of the Preferential Procurement Regulations, 2017 promulgated under the Policy Framework Act (PPPFA), 2000 (Act No. 5 of 2000).

SIGNATURE: \_\_\_\_\_

DATE: \_\_\_\_\_ 20.....

WITNESS No. 1 \_\_\_\_\_

DATE: \_\_\_\_\_ 20.....

WITNESS No. 2 \_\_\_\_\_

DATE: \_\_\_\_\_ 20.....

- 1 This Municipal Bidding Document must form part of all bids invited.
- 2 It serves as a declaration to be used by municipalities and municipal entities in ensuring that when goods and services are being procured, all reasonable steps are taken to combat the abuse of the supply chain management system.
- 3 The bid of any bidder may be rejected if that bidder, or any of its directors have:
  - a. abused the municipality's / municipal entity's supply chain management system or committed any improper conduct in relation to such system;
  - b. been convicted for fraud or corruption during the past five years;
  - c. willfully neglected, reneged on or failed to comply with any government, municipal or other public sector contract during the past five years; or
  - d. been listed in the Register for Tender Defaulters in terms of Schedule 29 of the Prevention and Combating of Corrupt Activities Act (No 12 of 2004).
- 4 **In order to give effect to the above, the following questionnaire must be completed and submitted with the bid.**

Item	Question	Yes	No
4.1	<p><b>Is the bidder or any of its directors listed on the National Treasury's Database of Restricted Suppliers as companies or persons prohibited from doing business with the public sector?</b>                      (Companies or persons who are listed on this Database were informed in writing of this restriction by the Accounting Officer/Authority of the institution that imposed the restriction after the <i>audi alteram partem</i> rule was applied).</p> <p><b>The Database of Restricted Suppliers now resides on the National Treasury's website(<a href="http://www.treasury.gov.za">www.treasury.gov.za</a>) and can be accessed by clicking on its link at the bottom of the home page.</b></p>	Yes <input type="checkbox"/>	No <input type="checkbox"/>
4.1.1	If so, furnish particulars:		
4.2	<p><b>Is the bidder or any of its directors listed on the Register for Tender Defaulters in terms of Schedule 29 of the Prevention and Combating of Corrupt Activities Act (No 12 of 2004)?</b>  <b>The Register for Tender Defaulters can be accessed on the National Treasury's website (<a href="http://www.treasury.gov.za">www.treasury.gov.za</a>) by clicking on its link at the bottom of the home page.</b></p>	Yes <input type="checkbox"/>	No <input type="checkbox"/>
4.2.1	If so, furnish particulars:		
4.3	<p><b>Was the bidder or any of its directors convicted by a court of law (including a court of law outside the Republic of South Africa) for fraud or corruption during the past five years?</b></p>	Yes <input type="checkbox"/>	No <input type="checkbox"/>
4.3.1	If so, furnish particulars:		
4.4	<p><b>Does the bidder or any of its directors owe any municipal rates and taxes or municipal charges to the municipality / municipal entity, or to any other municipality / municipal entity, that is in arrears for more than three months?</b></p>	Yes <input type="checkbox"/>	No <input type="checkbox"/>
4.4.1	If so, furnish particulars:		
4.5	<p><b>Was any contract between the bidder and the municipality / municipal entity or any other organ of state terminated during the past five years on account of failure to perform on or comply with the contract?</b></p>	Yes <input type="checkbox"/>	No <input type="checkbox"/>
4.7.1	If so, furnish particulars:		

**CERTIFICATION**

I, THE UNDERSIGNED (FULL NAME) .....  
 CERTIFY THAT THE INFORMATION FURNISHED ON THIS  
 DECLARATION FORM TRUE AND CORRECT.

I ACCEPT THAT, IN ADDITION TO CANCELLATION OF A CONTRACT, ACTION MAY BE TAKEN AGAINST ME SHOULD THIS DECLARATION PROVE TO BE FALSE.

.....20.....  
 Signature Date

.....  
 Position Name of Bidder

**SCHEDULE 08: MBD 9**

**CERTIFICATE OF INDEPENDENT BID DETERMINATION**

I, the undersigned, in submitting the accompanying bid:

\_\_\_\_\_

(Bid Number and Description)

in response to the invitation for the bid made by:

\_\_\_\_\_

(Name of Municipality / Municipal Entity)

do hereby make the following statements that I certify to be true and complete in every respect:

I certify, on behalf of: \_\_\_\_\_ that:

(Name of Bidder)

1. I have read and I understand the contents of this Certificate;
2. I understand that the accompanying bid will be disqualified if this Certificate is found not to be true and complete in every respect;
3. I am authorized by the bidder to sign this Certificate, and to submit the accompanying bid, on behalf of the bidder;
4. Each person whose signature appears on the accompanying bid has been authorized by the bidder to determine the terms of, and to sign, the bid, on behalf of the bidder;
5. For the purposes of this Certificate and the accompanying bid, I understand that the word "competitor" shall include any individual or organization, other than the bidder, whether or not affiliated with the bidder, who:
  - (a) has been requested to submit a bid in response to this bid invitation;
  - (b) could potentially submit a bid in response to this bid invitation, based on their qualifications, abilities or experience; and
  - (c) provides the same goods and services as the bidder and/or is in the same line of business as the bidder
6. The bidder has arrived at the accompanying bid independently from, and without consultation, communication, agreement or arrangement with any competitor. However, communication between partners in a joint venture or consortium<sup>3</sup> will not be construed as collusive bidding.
7. In particular, without limiting the generality of paragraphs 6 above, there has been no consultation, communication, agreement or arrangement with any competitor regarding:
  - (a) prices;
  - (b) geographical area where product or service will be rendered (market allocation)
  - (c) methods, factors or formulas used to calculate prices;
  - (d) the intention or decision to submit or not to submit, a bid;
  - (e) the submission of a bid which does not meet the specifications and conditions of the bid; or





## CONTRACT DETAILS

### DETAILS OF THE CONTRACT

This contract involves the Supply and replacement of Surge Arrestors on 66/11kV network/ transformers at Industrial Sub

#### Eligibility Criteria:

- ✚ Only those Contractors who are CIDB (Construction Industry Development Board) registered with a grading 3 - EP or higher are eligible to participate in this quote.
- ✚ Valid registration as Electrical Contractor in accordance with the Occupational Health and Safety Act [Registration 6(4)] at Department of Labour
- ✚ Who, according to the employer, do not present any commercial risk and can demonstrate that he or she possesses the professional and technical competence, financial resources, equipment and other physical facilities, reliability, and expertise to perform the contract
- ✚ Comply with the Occupational Health and Safety Act and Construction Regulations
- ✚ Comply with the COIDA (Compensation for Occupational Injuries and Diseases Act);
- ✚ Valid registration with the Compensation Commissioner
- ✚ Valid insurance at time of the project award – for the full duration of the project until completion (Public and Employers liability - comprehensive cover including due to defective workmanship, minimum value – R2m)
- ✚ Must have minimum 10 years previous experience on contracts of a similar value and nature. (contactable references of previous projects must be included)
- ✚ Compliance with required maximum completion period of 40 working days,
- ✚ Must be in own the necessary equipment to perform the work.
- ✚ Supervisory must have a Valid ORHVS certificate.
- ✚ **All relevant proof to be attached in Annexure A**

### PART A : DESCRIPTION OF WORKS

#### 1. EMPLOYERS OBJECTIVE:

The employer's objective is to procure the services an Electrical Contractor to Supply and replace the 11kV Surge Arrestors on 1Transformers at Industrial substations, service of transformer and online tap changer of 2 transformers, replace 2 Buchholz relay's and do secondary protection test on protection

The requested maintenance actions must be performed in accordance with applicable legislation and municipal procedure.

#### 2. WORK SCOPE:

##### a) Overview

- The contractor must supply and replace the existing surge arrester 11kV (set of 3) on Transformers 3 at Industrial Substation
- Contractor must supply, install and commission 2 Buchholz relay's per transformer (2 transformers)

- Contractor must service online tap changer (2 transformers)
- Contractor to take 2 oil samples per transformer (main tank and Buchholz of 2 transformers)
- One transformer at time can be decommissioned to perform the necessary task.
- Contractor must perform secondary protection test

**b) Scope**

**Transformer**

Visibly Check & record condition of Unit

Check condition of ceramic insulators

Check & record gas levels

Check for functionality of the buchholz relay and alarms

Check condition of conductors

Check overall condition of structure & mountings

Check condition of paint on control panel

Check that inside of control panel is clear of debris, ie rubbish, birds' nests, etc

Check that door hinges & doors are secure and locked on control panel

Perform a Tan Delta test and record results

Ensure that all earth straps/connections are connected, tight & in good order

Check & record CB schematic inside substation & report any abnormalities or relay operations

Check transformer connections for 'hotspots' (MV & HV)

Isolate & make installation safe in accordance with departmental safe work procedure

Check & clean entire transformer installation

Take a set of three oil samples and arrange for comprehensive analysis

Take a NER insulation medium sample and arrange for comprehensive analysis

Check electrical connections on secondary & primary sides

Check that all earth straps/connections are connected, tight & in good order

Touch up paint as required

A oil analyses must be performed on bottom tank and buchholz relay main tank (13 tests)

**Tap changer**

Take a set of three oil samples and arrange for comprehensive analysis

Drain tap changer oil

Check & clean entire tap changer installation

Check tap changer contacts & resistances for faults and wear

Inspect condition V-belt, change if worn

Test pressure control relay

Replace packing on cover, close & fill with clean oil (new virgin oil will be supplied by BVM)

Lubricate drive mechanism

Check that all earth straps/connections are connected, tight & in good order

## **Oil Sample**

The following will be tested at sample point:

Bottom Main Tank and Buchholz relay main tank

- 1) Dielectric strength
- 2) Water content
- 3) Acidity
- 4) DGA – Dissolved Gas Analysis

New sample tins must be used to minimize contamination

## **Protection Test**

**Secondary testing for:**

- 1) Over current
- 2) Earth fault
- 3) Differential

An report of the result by a competent person must be submitted at completion

### **c) Material (transformer 3 at Industrial)**

#### **11kV Surge Arrestors set of 3**

Rated Voltage: 12kV  
MCOV/Uc kV rms 10.2  
Line discharge: class 1  
Normal creepage distance: 480mm

#### **Buchholz relay (transformer 3 Industrial and transformer 2 at Robertson Road)**

2 Buchholz relays must be supplied, installed and commissioned. Same or similar of good quality must be supplied

See attached drawings specifications:

PR 5667 4006-1

PR 5667 4000

All material pertaining to the project must be supplied by the service provider and will be evaluated by the Electrical Services Department for standard compliance.

In the event of municipal materials being broken or misplaced due to Contractor negligence, the Contractor must replace material to the standard as provided.

Contractor must coordinate with the Electrical Services Department for return and exchange of any removed and defective materials. Defective and removed material shall be transported and returned to the Electrical Department by the Contractor.

The Contractor may not charge additional fees for transportation costs incurred during return of the defective materials.

### **d) Work Orders and Commissioning Forms**

A standard municipal work order (for each maintenance request) will be issued to the contractor. The work orders must be properly completed as per municipal standard. All completed work orders must be submitted to the Electrical Services Department on a weekly basis as stipulated by the Electrical Services Department.

**e) Authorization:**

The Head of Electrical Services Department will authorize the successful contractor to:

- operate standard municipal keys to gain access to the municipal substations and mini substations
- Authorization will ONLY be limited to the duration of said project.

**f) Inspection, Quality Control, Hours of Work.**

- The Municipal representative will be available from Monday to Friday during normal business hours to inspect Contractor work and to provide assistance with Contractor issues.
- All job cards or related requests (lists) completed will be returned to the Electrical Department on a weekly basis.
- Except in case of emergency or unless otherwise approved by the Engineer, the normal hours of work shall occur between 7:45 a.m. and 16:30 p.m. on any working day and shall consist of 8 hours, exclusive of a lunch period of not more than half an hour.
- No claim will be entertained for the working of unauthorized overtime, disruption, out of sequence activities, additional supervision and/ or plant which might be necessary to achieve the completion dates.

**g) Obligations of the Electrical Department.**

- The Electrical Services Department shall furnish the successful Contractor with the necessary order where the above-mentioned works are to be completed,
- Issue applicable working permits
- Conduct compliance and performance monitoring in respect of the delivery of the scope of work.  
The Department reserves the right to inspect or test any equipment or service that has been included for acceptance and payment and the contractor may require repair or replacement of the equipment or service that is not acceptable at no cost to the Department.

**h) Legislative compliance:**

- The Contractor shall be fully and solely responsible for ensuring compliance with the Occupational Health and Safety Act (Act no 85 of 1993) and any other legislation that may apply. In this regard it is specifically pointed out that the Contractor will, inter alia, have to do the following:
- Provide and maintain systems of work, plant and machinery that are safe and without risk to health.
- Eliminate or mitigate hazards or potential hazards before resorting to personal protective equipment.
- Ensure the safety and absence of risk in connection with the handling of articles or substances.
- Establish the hazards pertaining to work establish what precautions should be taken and provide the means to apply the precautions.
- Provide information, instructions, training and supervision to ensure health and safety.
- Not permit anyone to do anything unless the necessary precautions have been taken.
- Do everything possible to ensure compliance with the applicable legislation.
- Enforce discipline in the interest of health and safety.
- Ensure that work is performed, and plant or machinery is used under the supervision of a person with the necessary training and authority.
- Cause all employees to be informed of their authority in terms of section 37(1)(b) of the OHS Act.
- Conduct his undertaking in such a manner that he or any other persons are not exposed to hazards to their health and safety.

- It is also recorded that, in order to comply with legislation, the Contractor would have to appoint certain persons in writing, e.g. to supervise machinery, excavation work, stacking, etc. and to operate lifting gear and to investigate certain incidents. These people should have received special training and in some cases, they should be in possession of specified qualifications or hold prescribed certificates. It will be the responsibility of the Contractor to ascertain what the law requires and to ensure compliance.
- It is specifically recorded that the Contractor shall, in terms of section 37(2) of the Occupational Health and Safety Act, be fully and solely responsible for ensuring compliance with the provisions of this Act. Should the Contractor find anything in this specification or receive an instruction that may jeopardies his compliance with any legislation he shall bring such finding or instruction to the attention of the Breede Valley Municipality and resolve the matter before proceeding.
- It is further specifically pointed out that the Contractor shall be registered in terms of the Compensation for Occupational Injuries and Diseases Act (Act No. 130 of 1993) and that he shall be in good standing with respect to the payment of assessments to the Compensation Commissioner.
- In terms of regulation 4(3) of the Construction Regulations, 2003 (hereinafter referred to as the Regulations), promulgated on 18 July 2003 in terms of Section 43 of the Occupational Health and Safety Act, 1993 (Act No 85 of 1993) the Employer shall not appoint a contractor to perform construction work unless the Contractor can satisfy the Employer that his/her firm has the necessary competencies and resources to carry out the work safely and has allowed adequately in his/her bid for the due fulfilment of all the applicable requirements of the Act and the Regulations.
- Adhere to the latest Construction Regulations as per above OHS Act
- The work will be carried out strictly in accordance with the latest issue of the following documents:
- The SANS 0142/1 Code of Practice for the Wiring of Premises
- The Occupational Health and Safety Act, 1993 (Act 85 of 1993)
- The municipal By-Laws
- Electricity Act, 1987 (Act 41 of 1987) (as amended). (Note, particularly, Government Gazette R103, 26 January 1996).
- Any reasonable special requirements of the Head of Department – Electrical Services or his/her duly authorized representative.

#### **i) Electrical Switching**

The contractor shall make the necessary arrangements with the municipality for the power to be switched off and earthed before any work is carried out near the live equipment. A work permit, that states that the power is off, and that all relevant switchgear has been locked out, will be issued to the contractor. The permit must be signed by the responsible parties and a description must be noted of the equipment isolated and earthed in accordance with the OHS Act. This needs to be completed before any work commences.

Adequate precautions must be taken to ensure that the permit is not signed off prematurely and/or that somebody does not return to a job after the permit has been signed off.

The contractor shall, before requesting the municipality to make any equipment live, conduct a thorough inspection of the entire work area to ensure that all personnel, equipment and tools has been safely removed into a safe distance from the overhead lines.

#### **j) Standard of work**

All electrical maintenance must be performed in strict compliance as per Construction Regulation, OHS Act and all applicable legislation.

#### **k) Non-Performance**

In the event of that the Contractor is in default in the form of non-performance of its obligations in term of this Agreement, the Contractor shall be liable for any loss or damages caused to the municipality or a third party, unless such non-performance is caused by an occurrence beyond the reasonable control of the Contractor, such as accidents, theft, vandalism, force majeure etc.

**l) Duration:**

The project must be fully completed within a maximum period of one 40 working days from the date the representative and contractor has agreed on.

**m) Conduct:**

- If unsure about the legality of an instruction, the contractor shall seek clarity from the Electrical Services Department.
- Under no circumstances shall the contractor perform any function that he or she is not authorized to perform. In any case of doubt, the matter shall be referred to the Electrical Services Department.
- Municipal consumers shall always be addressed in a respectful and courteous manner.
- The contractor's teams shall not retaliate when subjected to abuse by an irate consumer. In the event of any abuse, this shall be referred to the Electrical Services Department.
- The contractor's staff, including skilled, semi-skilled and unskilled staff, shall be appropriately dressed.
- The contractor's teams must be fully equipped with all the necessary equipment and personal protective equipment (PPE) in terms of the Occupational Health and Safety Act.
- Must be contactable during the installation and construction period
- Must available to attend weekly meetings with the Electrical Services Department to give updates, discuss progress and any problem related queries pertaining to the project.

**n) Liability:**

- The successful contractor shall be held liable for all specified installation work conducted by the work teams on a consumer's premises.
- The contractor shall be responsible for the costs incurred in cases of loss or damage to private - and or municipal property if sufficient evidence is submitted to substantiate a consumer's and / or a municipal claim for monetary compensation.
- The successful contractor shall be responsible for the safeguard costs of the work teams (including any security measures).
- The successful contractor shall be responsible for all costs in the event of loss and damage of its own tools and equipment in the execution of tasks / activities during the project period
- It will be expected that the contractor performs consistent installations for the full duration of the project in the entire flat complex without any hindrance.

**o) Compliance prerequisites:**

- Compliance inspections of the completed work will be randomly performed by the Electrical Services Department
- The inspections must be successfully conducted, and zero installation deviations must be adhered to.

**p) Obligations of the Electrical Department.**

- The Electrical Department shall furnish the successful Contractor with the necessary work orders, work permits and lists where the above-mentioned works are to be completed, note that the Contractor bears the responsibility for any liaison and arrangements with the consumers regarding the works process.
- Allow full access to the Low Voltage Distribution Equipment (limited to public lighting infrastructure)
- Conduct audit and performance monitoring in respect of the delivery of the scope of work.
- The Department reserves the right to inspect or test any equipment or installation that has been included for acceptance and payment and the contractor may require repair or replacement of the equipment or service that is not acceptable at no cost to the Department.

**q) Special Conditions:**

- A compulsory site meeting will be required to assess the extent of the project scope and expenditure for quotation purposes
- The workmanship must be guaranteed for a period of 1 (one) year after the successful completion of the project.
- No subcontracting will be permitted

**3. MEASUREMENT AND PAYMENT**

a) Method of payment

Except where otherwise specified in the specifications or in the preamble to the schedule, all items in the schedule shall be measured and shall cover the operation as specified.

b) Quoted Unit Cost

The summative quoted cost in the schedule of quantities shall cover the Contractor's direct and overhead cost and profit and all other costs of complying with the obligations, liabilities, risks and requirements associated with such item

**4. PAYMENT**

a) Terms of Payment

Where indicated where pricing is based on a unit price for each individual scheduled item, that includes costs of:

- labor and traveling costs,
- all forms of idle time
- tools, equipment and PPE
- all activities related to legal and regulatory compliances
- ablution and latrine facilities or access to such facilities

Pricing must also include all the costs of consumable items, plant hire, maintenance, depreciation and all other coincidences that shall be necessary to complete the project as specified.

The pricing must also include all the overhead costs, profits, site supervision, insurance, holidays with payment, travelling costs (or travelling allowances) and residence allowances of operators and any other allowances that is applicable. No further percentage allowances shall be applicable on equipment.

Quantities may fluctuate due to operational requirements and additional extensions to the existing network.

The terms of payment shall conform to the relevant clauses of the applicable conditions of contract.

## 5. COMPLETION PERIOD

Works shall be completed within 40 working days from commencement date. A grace period of up to 10 working days shall be granted, at the discretion of the Project Manager, to cater for acts of God (inclement weather and any other occurrence that could not have been foreseen during the quotation process). Failure to meet the contractual obligations shall result in the municipality having to impose a penalty of R1000.00 for every day that is late, after the grace period has been depleted.

Records of failing to honour the contractual obligations shall be kept and used for the purposes of evaluating future quotations and tenders.

## 6. Pre-Qualification Criteria

(All relevant proof to be attached with bid Annexure A)

1. Supervisor/Team Leader must be in possession of a Valid ORHVS certificate and be appointed as Responsible person.
2. All equipment for the relevant job to be specified and where necessary calibration and test certificate must be supplied with this bid.
3. All team members qualification and work experience to be attached with bid.
4. Supervisor/Team Leader to have at least 10 Years' experience in maintenance and construction of 66/11kV transformer and associated equipment.
5. Full specification on material that will be supplied.

**Failure to supply following documentation will mark this bid unresponsive**



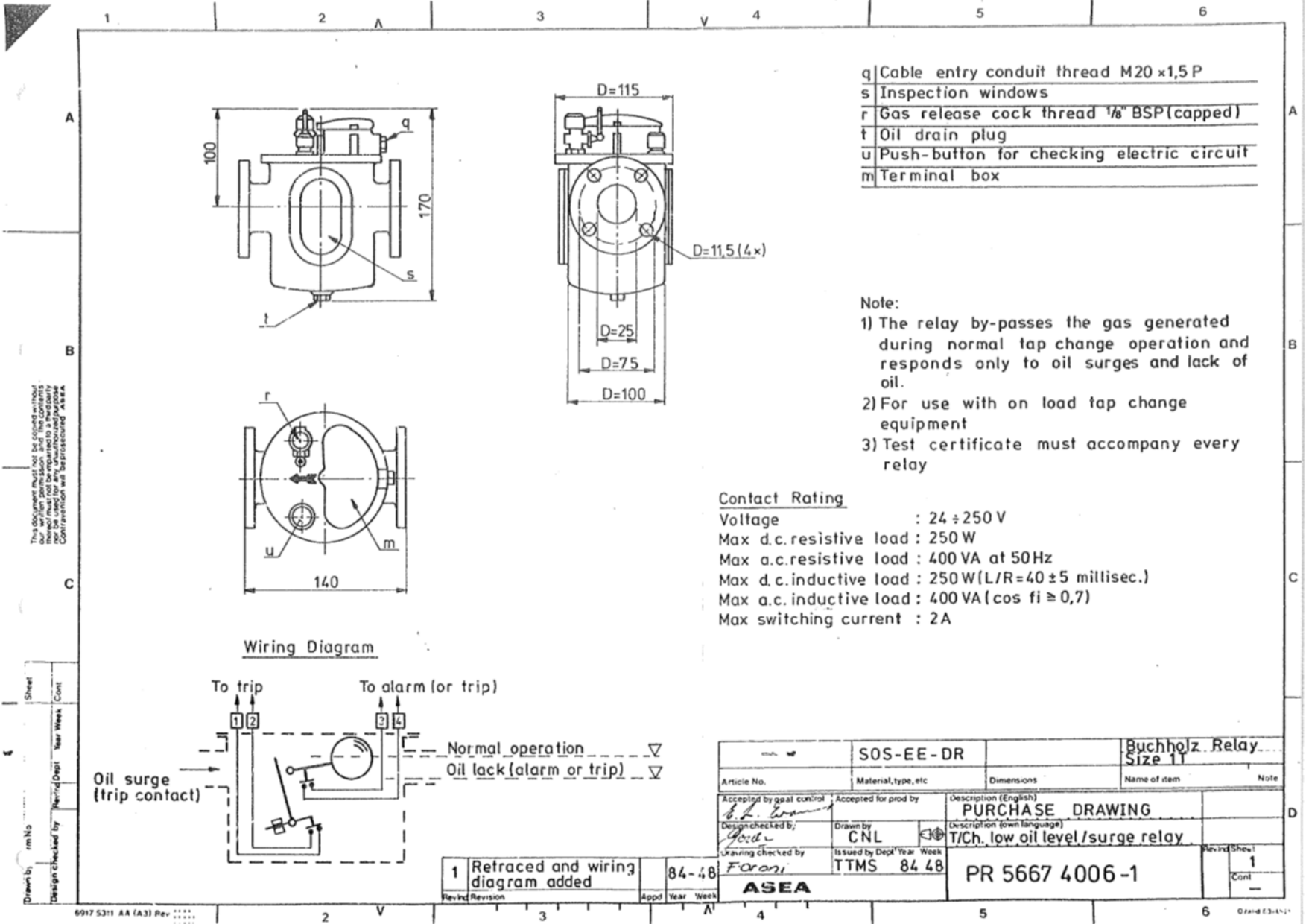

q	Cable entry conduit thread M20 x1,5 P
s	Inspection windows
r	Gas release cock thread 1/8" BSP (capped)
t	Oil drain plug
u	Push-button for checking electric circuit
m	Terminal box

**Note:**

- 1) The relay by-passes the gas generated during normal tap change operation and responds only to oil surges and lack of oil.
- 2) For use with on load tap change equipment
- 3) Test certificate must accompany every relay

**Contact Rating**

Voltage : 24 ÷ 250 V  
 Max d.c.resistive load : 250 W  
 Max a.c.resistive load : 400 VA at 50Hz  
 Max d.c.inductive load : 250 W(L/R=40 ± 5 millise.)  
 Max a.c. inductive load : 400 VA (cos fi ≥ 0,7)  
 Max switching current : 2 A

Wiring Diagram

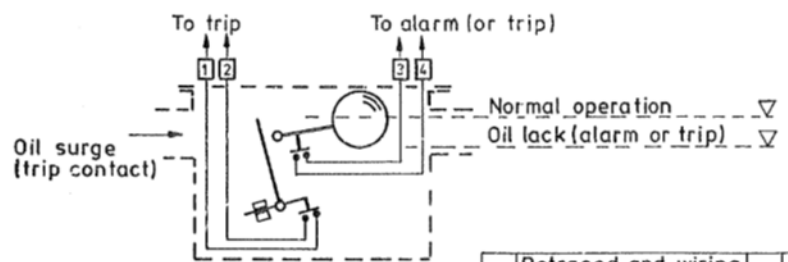

This document must not be copied without our written permission and the contents may not be used for any unauthorized purpose. Contravention will be prosecuted. ASEA

Drawn by: [ ]  
 Design checked by: [ ]  
 Rev'd/Dep't Year Week Cont

1	Retraced and wiring diagram added	84-48
Rev'd/Revision	App'd Year Week	

Article No.	SOS-EE-DR	Dimensions	Buchholz Relay... Size 11
Accepted by qual control	Accepted for prod by	Description (English)	Note
Design checked by: [ ]	Drawn by: CNL	<b>PURCHASE DRAWING</b>	
Drawn checked by: [ ]	Issued by Dep't Year Week	Description (own language)	
	TTMS 84 48	T/Ch. low oil level/surge relay	
PR 5667 4006-1			Rev'd Sheet 1 Cont

This document must not be copied without our written permission and the contents hereof are not to be used for any unauthorized purpose. Contravention will be prosecuted. ASEA

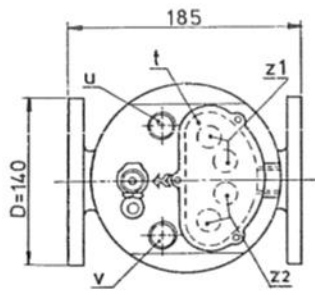
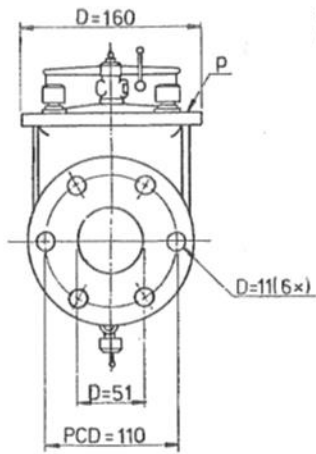
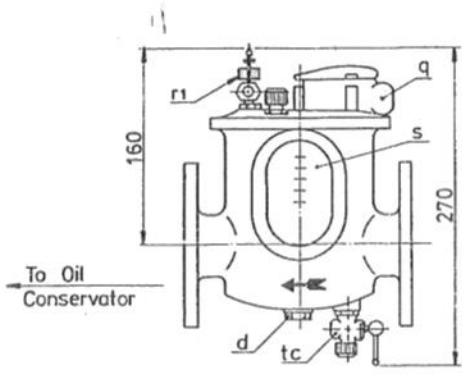

- p Machined surface
- q Hole tapped conduit thd. M20 x 1,5p
- r1 Gas release cock thd 1/4" BSP
- d Oil drain plug
- s Inspection windows
- t Terminal box
- u Small valve for checking the alarm switch by means of air under pressure
- v Push button for checking the switches
- z1 Terminals for trip
- z2 Terminals for alarm
- tc Test cock for checking the trip switch by means of air under pressure thd 1/4" BSP

**NOTE:-**

- 1) Relay to be fitted with required magnetic Reed switches.
- 2) Each relay to be identified by a serial number.
- 3) A test certificate to accompany each relay.
- 4) Suppliers reference SOS-EE-DR.
- 5) Antiseismic version Aspe Type Size 2".
- 6) A maximum tilt of 2 to 4 on the horizontal axis can be allowed towards the conservator
- 7) Transformer total oil content 1001 to 10 000 litres.

**Contact Rating**

- Voltage : 24 + 250V
- Max d.c. resistive load : 250 W
- Max a.c. resistive load : 400 VA at 50Hz
- Max d.c. inductive load : 250 W (L/R=40 ± 5 milisec.)
- Max a.c. inductive load : 400 VA at 50 Hz.
- Max switching current : 2A

Wiring Diagram  
Contact position when the relay is oil filled

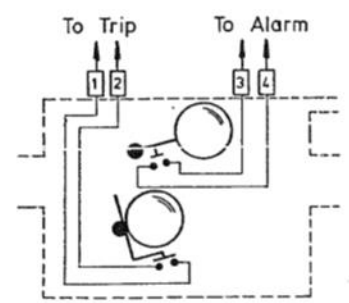

Mass = 8,85kg

Article No.		Material, type, etc	Dimensions	Name of item	Note
Accepted for prod by		Accepted for prod by		Description (English)	
Checked by		Checked by		Description (own language)	
Drawing checked by		Issued by Dept' Year Week		Revised Sheet	
2 COMPLETELY REDRAWN		TTMS 87 35		1	
Revised/Revision		App'd Year Week		Cont	
		ASEA		PR 5667 4000	

**PRICING INSTRUCTION:**

Schedule of Quantities:

Item	Description	Unit	Quantity	Unit Price	Price
1	Maintenance on Transformer NO 3 Industrial Substation as set out in Scope	Each	1		
2	Maintenance on Transformer NO 2 Robertson Road Substation as set out in Scope	Each	1		
3	Contingencies	%	10		
Total					
4	Safety File	Each	1		
VAT @ 15%					
Total Price					



**BREEDE VALLEY**  
MUNICIPALITY • MUNISIPALITEIT • UMASIPALA

30 Baring Street, Worcester, Western Cape,  
South Africa, 6849, Private Bag X3046

**A caring valley of excellence.**



## Annexure A

Proof of documentation as mentioned in paragraph 6 Pre-Qualification Criteria and Eligibility Criteria

## SPECIAL CONDITIONS

- The successful Service Providers or Contractor/s shall be responsible for the procurement of all the necessary materials and labour required for the execution of the works.
- The successful contractor shall ensure that competent and knowledgeable team member(s) are the ones that execute the work at all times. No qualified artisan shall be substituted by an unqualified member at any given time.
- No work shall be undertaken, unless instructed by the authorised representative of the employer.
- The successful contractor shall at all times practice safe working habits and create safe working conditions for his/her workers. Protective clothing shall be worn when executing work. The municipality shall be indemnified against any loss, injury to employees and damage to own property or third party, while executing the works on behalf of the municipality.
- No subcontracting will be allowed for the main component of this tender. If the contractor is unable to perform the assigned task at any given time, the municipality will be at liberty to consider the second highest bidder in order to avoid service delivery being hampered.
- Bidders must attach proof of registration/insurance in terms of the Compensation for Occupational Injuries and Disease Act, Act 130 of 1993. This can either take the form of a certified copy of a valid Letter of Good Standing issued by the Compensation Commissioner, or proof of insurance with a licenced compensation insurer, from either the tenderer's broker or the insurance company itself. No award shall be made to the bidder who is not in good standing with the Compensation Commissioner, or cannot prove to have been registered.
- The municipality reserves the right to conduct an assessment on the recommended bidder's ability to execute the task. Such an assessment will be based on (but not limited to):
  - Ability to handle a project of similar nature and size (experience);
  - Ability to access tools and vehicle;
  - Ability to access funding and other related resources; etc.
- Prior to the award, the municipality reserves the right to inspect the contractors/ service providers premises & equipment and to conduct verifications on the recommended contractor in order to ensure that technical and financial risks are eliminated.
- No Progress (Part) payments shall be done. The municipality shall do payments upon successful completion of the required works. Before a payment will be done, an inspection will be done to the satisfaction of the municipality.
- No payment shall be made on incomplete or poor workmanship. All workmanship shall have a guarantee of 12 months
- Invoices shall be paid within 30 days from receipt, after the works have been certified to be in order.
- The municipality reserves the right to terminate the contract should no satisfaction be received from the successful bidder.
- Service providers/ contractors must provide at least two references (contact details and addresses) where previous works of similar nature and size, were done.
- Contractors must make provision for own storage and security of material, tools and equipment, during the course of the project.
- Any damages to the municipal building caused by Service provider / contractor while on site will be for his/her own account, any must be repaired at the cost of the contractor.
- Service providers may form a joint venture or consortium, however, no sub-contracting for the works shall be allowed. (NO EXCEPTION)
- The municipality reserves the right to cancel or reduce the scope of works at its discretion in order to meet the budget limitations.
- Bidders must provide at least two references (contact details and addresses) where previous similar projects were done

## **COMMENCEMENT OF THE WORKS**

Works shall commence within 14 working days from date of receiving an official order. Failure to do so shall result in the municipality having to cancel an order and consider appointing the second highest bidder. Records of failing to honour the contractual obligations shall be kept and used for the purposes of evaluating future quotations and tenders.

## **DELIVERY PERIOD**

Delivery shall be completed within the time period as stated by the supplier / service provider from date of commencement. Failure to meet the contractual obligations shall result in the municipality having to impose a penalty of R300.00 for every day that is late, after the grace period has been depleted.

Records of failing to honour the contractual obligations shall be kept and used for the purposes of evaluating future quotations and tenders.

# GENERAL CONDITIONS OF CONTRACT

## TABLE OF CLAUSES

1.	Definitions
2.	Application
3.	General
4.	Standards
5.	Use of contract documents and information inspection
6.	Patent Rights
7.	Performance security
8.	Inspections, tests and analyses
9.	Packing
10.	Delivery and documents
11.	Insurance
12.	Transportation
13.	Incidental Services
14.	Spare parts
15.	Warranty
16.	Payment
17.	Prices
18.	Variation orders
19.	Assignment
20.	Subcontracts
21.	Delays in the supplier's performance
22.	Penalties
23.	Termination for default
24.	Anti-dumping and countervailing duties and rights
25.	Force Majeure
26.	Termination for insolvency
27.	Settlement of Disputes
28.	Limitation of Liability
29.	Governing language
30.	Applicable law
31.	Notices
32.	Taxes and duties
33.	Transfer of contracts
34.	Amendments of contracts
35.	Prohibition of restrictive practices

## General Conditions of Contract (GCC)

### 1. Definitions

1. The following terms shall be interpreted as indicated:

- 1.1 "Closing time" means the date and hour specified in the bidding documents for the receipt of bids.
- 1.2 "Contract" means the written agreement entered into between the purchaser and the supplier, as recorded in the contract form signed by the parties, including all attachments and appendices thereto and all documents incorporated by reference therein.
- 1.3 "Contract price" means the price payable to the supplier under the contract for the full and proper performance of his contractual obligations.
- 1.4 "Corrupt practice" means the offering, giving, receiving, or soliciting of anything of value to influence the action of a public official in the procurement process or in contract execution.
- 1.5 "Countervailing duties" are imposed in cases where an enterprise abroad is subsidized by its government and encouraged to market its products internationally.
- 1.6 "Country of origin" means the place where the goods were mined, grown or produced or from which the services are supplied. Goods are produced when, through manufacturing, processing or substantial and major assembly of components, a commercially recognized new product results that is substantially different in basic characteristics or in purpose or utility from its components.
- 1.7 "Day" means calendar day.
- 1.8 "Delivery" means delivery in compliance of the conditions of the contract or order.
- 1.9 "Delivery ex stock" means immediate delivery directly from stock actually on hand.
- 1.10 "Delivery into consignees store or to his site" means delivered and unloaded in the specified store or depot or on the specified site in compliance with the conditions of the contract or order, the supplier bearing all risks and charges involved until the goods are so delivered and a valid receipt is obtained.
- 1.11 "Dumping" occurs when a private enterprise abroad market its goods on own initiative in the RSA at lower prices than that of the country of origin and which have the potential to harm the local industries in the RSA.
- 1.12 "Force majeure" means an event beyond the control of the supplier and not involving the supplier's fault or negligence and not foreseeable. Such events may include, but is not restricted to, acts of the purchaser in its sovereign capacity, wars or revolutions, fires, floods, epidemics, quarantine restrictions and freight embargoes.
- 1.13 "Fraudulent practice" means a misrepresentation of facts in order to influence a procurement process or the execution of a contract to the detriment of any bidder, and includes collusive practice among bidders (prior to or after bid submission) designed to establish bid prices at artificial non-competitive levels and to deprive the bidder of the benefits of free and open competition.
- 1.14 "GCC" means the General Conditions of Contract.
- 1.15 "Goods" means all of the equipment, machinery, and/or other materials that the supplier is required to supply to the purchaser under the contract.



- 1.16 "Imported content" means that portion of the bidding price represented by the cost of components, parts or materials which have been or are still to be imported (whether by the supplier or his subcontractors) and which costs are inclusive of the costs abroad, plus freight and other direct importation costs such as landing costs, dock dues, import duty, sales duty or other similar tax or duty at the South African place of entry as well as transportation and handling charges to the factory in the Republic where the goods covered by the bid will be manufactured.
- 1.17 "Local content" means that portion of the bidding price, which is not included in the imported content provided that local manufacture does take place.
- 1.18 "Manufacture" means the production of products in a factory using labour, materials, components and machinery and includes other related value-adding activities.
- 1.19 "Order" means an official written order issued for the supply of goods or works or the rendering of a service.
- 1.20 "Project site," where applicable, means the place indicated in bidding documents.
- 1.21 "Purchaser" means the organization purchasing the goods.
- 1.22 "Republic" means the Republic of South Africa.
- 1.23 "SCC" means the Special Conditions of Contract.
- 1.24 "Services" means those functional services ancillary to the supply of the goods, such as transportation and any other incidental services, such as installation, commissioning, provision of technical assistance, training, catering, gardening, security, maintenance and other such obligations of the supplier covered under the contract.
- 1.25 "Supplier" means the successful bidder who is awarded the contract to maintain and administer the required and specified service(s) to the State.
- 1.26 "Tort" means in breach of contract.
- 1.27 "Turnkey" means a procurement process where one service provider assumes total responsibility for all aspects of the project and delivers the full end product / service required by the contract.
- 1.28 "Written" or "in writing" means hand-written in ink or any form of electronic or mechanical writing.

## **2. Application**

- 2.1 These general conditions are applicable to all bids, contracts and orders including bids for functional and professional services (excluding professional services related to the building and construction industry), sales, hiring, letting and the granting or acquiring of rights, but excluding immovable property, unless otherwise indicated in the bidding documents
- 2.2 Where applicable, special conditions of contract are also laid down to cover specific goods, services or works.
- 2.3 Where such special conditions of contract are in conflict with these general conditions, the special conditions shall apply.

### **3 General**

- 3.1 Unless otherwise indicated in the bidding documents, the purchaser shall not be liable for any expense incurred in the preparation and submission of a bid. Where applicable a non refundable fee for documents may be charged.
- 3.2 Invitations to bid are usually published in locally distributed news media and on the municipality/municipal entity website.

### **4. Standards**

- 4.1 The goods supplied shall conform to the standards mentioned in the bidding documents and specifications.

### **5. Use of contract documents and information inspection**

- 5.1 The supplier shall not, without the purchaser's prior written consent, disclose the contract, or any provision thereof, or any specification, plan, drawing, pattern, sample, or information furnished by or on behalf of the purchaser in connection therewith, to any person other than a person employed by the supplier in the performance of the contract. Disclosure to any such employed person shall be made in confidence and shall extend only so far as may be necessary for purposes of such performance.
- 5.2 The supplier shall not, without the purchaser's prior written consent, make use of any document or information mentioned in GCC clause 5.1 except for purposes of performing the contract.
- 5.3 Any document, other than the contract itself mentioned in GCC clause 5.1 shall remain the property of the purchaser and shall be returned (all copies) to the purchaser on completion of the supplier's performance under the contract if so required by the purchaser.
- 5.4 The supplier shall permit the purchaser to inspect the supplier's records relating to the performance of the supplier and to have them audited by auditors appointed by the purchaser, if so required by the purchaser.

### **6. Patent Rights**

- 6.1 The supplier shall indemnify the purchaser against all third-party claims of infringement of patent, trademark, or industrial design rights arising from use of the goods or any part thereof by the purchaser.
- 6.2 When a supplier developed documentation / projects for the municipality / municipal entity, the intellectual, copy and patent rights or ownership of such documents or projects will vest in the municipality / municipal entity.

### **7. Performance Security**

- 7.1 Within thirty (30) days of receipt of the notification of contract award, the successful bidder shall furnish to the purchaser the performance security of the amount specified in SCC.
- 7.2 The proceeds of the performance security shall be payable to the purchaser as compensation for any loss resulting from the supplier's failure to complete his obligations under the contract.
- 7.3 The performance security shall be denominated in the currency of the contract, or in a freely convertible currency acceptable to the purchaser and shall be in one of the following forms:
  - (a) a bank guarantee or an irrevocable letter of credit issued by a reputable bank located in the purchaser's country or abroad, acceptable to the purchaser, in the form provided in the bidding documents or another form acceptable to the purchaser; or
  - (b) a cashier's or certified cheque.

7.4 The performance security will be discharged by the purchaser and returned to the supplier not later than thirty (30) days following the date of completion of the supplier's performance obligations under the contract, including any warranty obligations, unless otherwise specified.

## **8. Inspections, tests and analyses**

8.1 All pre-bidding testing will be for the account of the bidder.

8.2 If it is a bid condition that goods to be produced or services to be rendered should at any stage be subject to inspections, tests and analyses, the bidder or contractor's premises shall be open, at all reasonable hours, for inspection by a representative of the purchaser or organization acting on behalf of the purchaser.

8.3 If there are no inspection requirements indicated in the bidding documents and no mention is made in the contract, but during the contract period it is decided that inspections shall be carried out, the purchaser shall itself make the necessary arrangements, including payment arrangements with the testing authority concerned.

8.4 If the inspections, tests and analyses referred to in clauses 8.2 and 8.3 show the goods to be in accordance with the contract requirements, the cost of the inspections, tests and analyses shall be defrayed by the purchaser.

8.5 Where the goods or services referred to in clauses 8.2 and 8.3 do not comply with the contract requirements, irrespective of whether such goods or services are accepted or not, the cost in connection with these inspections, tests or analyses shall be defrayed by the supplier.

8.6 Goods and services which are referred to in clauses 8.2 and 8.3 and which do not comply with the contract requirements may be rejected.

8.7 Any contract goods may on or after delivery be inspected, tested or analysed and may be rejected if found not to comply with the requirements of the contract. Such rejected goods shall be held at the cost and risk of the supplier who shall, when called upon, remove them immediately at his own cost and forthwith substitute them with goods, which do comply with the requirements of the contract. Failing such removal the rejected goods shall be returned at the suppliers cost and risk. Should the supplier fail to provide the substitute goods forthwith, the purchaser may, without giving the supplier further opportunity to substitute the rejected goods, purchase such goods as may be necessary at the expense of the supplier.

8.8 The provisions of clauses 8.4 to 8.7 shall not prejudice the right of the purchaser to cancel the contract on account of a breach of the conditions thereof, or to act in terms of Clause 22 of GCC.

## **9. Packing**

9.1 The supplier shall provide such packing of the goods as is required to prevent their damage or deterioration during transit to their final destination, as indicated in the contract. The packing shall be sufficient to withstand, without limitation, rough handling during transit and exposure to extreme temperatures, salt and precipitation during transit, and open storage. Packing, case size weights shall take into consideration, where appropriate, the remoteness of the goods' final destination and the absence of heavy handling facilities at all points in transit.

9.2 The packing, marking, and documentation within and outside the packages shall comply strictly with such special requirements as shall be expressly provided for in the contract, including additional requirements, if any, and in any subsequent instructions ordered by the purchaser.

## **10. Delivery and documents**

10.1 Delivery of the goods and arrangements for shipping and clearance obligations, shall be made by the supplier in accordance with the terms specified in the contract.

## **11. Insurance**

11.1 The goods supplied under the contract shall be fully insured in a freely convertible currency against loss or damage incidental to manufacture or acquisition, transportation, storage and delivery in the manner specified.

## **12. Transportation**

12.1 Should a price other than an all-inclusive delivered price be required, this shall be specified.

## **13. Incidental Services**

13.1 The supplier may be required to provide any or all of the following services, including additional services, if any:

- (a) performance or supervision of on-site assembly and/or commissioning of the supplied goods;
- (b) furnishing of tools required for assembly and/or maintenance of the supplied goods;
- (c) furnishing of a detailed operations and maintenance manual for each appropriate unit of the supplied goods;
- (d) performance or supervision or maintenance and/or repair of the supplied goods, for a period of time agreed by the parties, provided that this service shall not relieve the supplier of any warranty obligations under this contract; and
- (e) training of the purchaser's personnel, at the supplier's plant and/or on-site, in assembly, start-up, operation, maintenance, and/or repair of the supplied goods.

13.2 Prices charged by the supplier for incidental services, if not included in the contract price for the goods, shall be agreed upon in advance by the parties and shall not exceed the prevailing rates charged to other parties by the supplier for similar services.

## **14. Spare parts**

14.1 As specified, the supplier may be required to provide any or all of the following materials, notifications, and information pertaining to spare parts manufactured or distributed by the supplier:

- (a) such spare parts as the purchaser may elect to purchase from the supplier, provided that this election shall not relieve the supplier of any warranty obligations under the contract; and
- (b) in the event of termination of production of the spare parts:
  - (i) advance notification to the purchaser of the pending termination, in sufficient time to permit the purchaser to procure needed requirements; and
  - (ii) following such termination, furnishing at no cost to the purchaser, the blueprints, drawings, and specifications of the spare parts, if requested.

## **15. Warranty**

15.1 The supplier warrants that the goods supplied under the contract are new, unused, of the most recent or current models, and that they incorporate all recent improvements in design and materials unless provided otherwise in the contract. The supplier further warrants that all goods supplied under this contract shall have no defect, arising from design, materials, or workmanship (except when the design and/or material is required by the purchaser's specifications) or from any act or omission of the supplier, that may develop under normal use of the supplied goods in the conditions prevailing in the country of final destination.

- 15.2 This warranty shall remain valid for twelve (12) months after the goods, or any portion thereof as the case may be, have been delivered to and accepted at the final destination indicated in the contract, or for eighteen (18) months after the date of shipment from the port or place of loading in the source country, whichever period concludes earlier, unless specified otherwise.
- 15.3 The purchaser shall promptly notify the supplier in writing of any claims arising under this warranty.
- 15.4 Upon receipt of such notice, the supplier shall, within the period specified and with all reasonable speed, repair or replace the defective goods or parts thereof, without costs to the purchaser.
- 15.5 If the supplier, having been notified, fails to remedy the defect(s) within the period specified, the purchaser may proceed to take such remedial action as may be necessary, at the supplier's risk and expense and without prejudice to any other rights which the purchaser may have against the supplier under the contract.

## **16. Payment**

- 16.1 The method and conditions of payment to be made to the supplier under this contract shall be specified.
- 16.2 The supplier shall furnish the purchaser with an invoice accompanied by a copy of the delivery note and upon fulfilment of other obligations stipulated in the contract.
- 16.3 Payments shall be made promptly by the purchaser, but in no case later than thirty (30) days after submission of an invoice or claim by the supplier.
- 16.4 Payment will be made in Rand unless otherwise stipulated.

## **17. Prices**

- 17.1 Prices charged by the supplier for goods delivered and services performed under the contract shall not vary from the prices quoted by the supplier in his bid, with the exception of any price adjustments authorized or in the purchaser's request for bid validity extension, as the case may be.

## **18. Variation orders**

- 18.1 In cases where the estimated value of the envisaged changes in purchase does not vary more than 15% of the total value of the original contract, the contractor may be instructed to deliver the goods or render the services as such. In cases of measurable quantities, the contractor may be approached to reduce the unit price, and such offers may be accepted provided that there is no escalation in price.

## **19. Assignment**

- 19.1 The supplier shall not assign, in whole or in part, its obligations to perform under the contract, except with the purchaser's prior written consent.

## **20. Subcontracts**

- 20.1 The supplier shall notify the purchaser in writing of all subcontracts awarded under this contract if not already specified in the bid. Such notification, in the original bid or later, shall not relieve the supplier from any liability or obligation under the contract.

## **21. Delays in the supplier's performance**

- 21.1 Delivery of the goods and performance of services shall be made by the supplier in accordance with the time Schedule prescribed by the purchaser in the contract.
- 21.2 If at any time during performance of the contract, the supplier or its subcontractor(s) should encounter conditions impeding timely delivery of the goods and performance of services, the supplier shall promptly notify the purchaser in writing of the fact of the delay, its likely duration and its cause(s). As soon as

practicable after receipt of the supplier's notice, the purchaser shall evaluate the situation and may at his discretion extend the supplier's time for performance, with or without the imposition of penalties, in which case the extension shall be ratified by the parties by amendment of contract.

- 21.3 The right is reserved to procure outside of the contract small quantities or to have minor essential services executed if an emergency arises, the supplier's point of supply is not situated at or near the place where the goods are required, or the supplier's services are not readily available.
- 21.4 Except as provided under GCC Clause 25, a delay by the supplier in the performance of its delivery obligations shall render the supplier liable to the imposition of penalties, pursuant to GCC Clause 22, unless an extension of time is agreed upon pursuant to GCC Clause 22.2 without the application of penalties.
- 21.5 Upon any delay beyond the delivery period in the case of a goods contract, the purchaser shall, without cancelling the contract, be entitled to purchase goods of a similar quality and up to the same quantity in substitution of the goods not supplied in conformity with the contract and to return any goods delivered later at the supplier's expense and risk, or to cancel the contract and buy such goods as may be required to complete the contract and without prejudice to his other rights, be entitled to claim damages from the supplier.

## **22. Penalties**

- 22.1 Subject to GCC Clause 25, if the supplier fails to deliver any or all of the goods or to perform the services within the period(s) specified in the contract, the purchaser shall, without prejudice to its other remedies under the contract, deduct from the contract price, as a penalty, a sum calculated on the delivered price of the delayed goods or unperformed services using the current prime interest rate calculated for each day of the delay until actual delivery or performance. The purchaser may also consider termination of the contract pursuant to GCC Clause 23.

## **23. Termination for default**

- 23.1 The purchaser, without prejudice to any other remedy for breach of contract, by written notice of default sent to the supplier, may terminate this contract in whole or in part:
- (a) if the supplier fails to deliver any or all of the goods within the period(s) specified in the contract, or within any extension thereof granted by the purchaser pursuant to GCC Clause 21.2;
  - (b) if the supplier fails to perform any other obligation(s) under the contract; or
  - (c) if the supplier, in the judgement of the purchaser, has engaged in corrupt or fraudulent practices in competing for or in executing the contract.
- 23.2 In the event the purchaser terminates the contract in whole or in part, the purchaser may procure, upon such terms and in such manner, as it deems appropriate, goods, works or services similar to those undelivered, and the supplier shall be liable to the purchaser for any excess costs for such similar goods, works or services. However, the supplier shall continue performance of the contract to the extent not terminated.
- 23.3 Where the purchaser terminates the contract in whole or in part, the purchaser may decide to impose a restriction penalty on the supplier by prohibiting such supplier from doing business with the public sector for a period not exceeding 10 years.
- 23.4 If a purchaser intends imposing a restriction on a supplier or any person associated with the supplier, the supplier will be allowed a time period of not more than fourteen (14) days to provide reasons why the envisaged restriction should not be imposed. Should the supplier fail to respond within the stipulated

fourteen (14) days the purchaser may regard the supplier as having no objection and proceed with the restriction.

- 23.5 Any restriction imposed on any person by the purchaser will, at the discretion of the purchaser, also be applicable to any other enterprise or any partner, manager, director or other person who wholly or partly exercises or exercised or may exercise control over the enterprise of the first-mentioned person, and with which enterprise or person the first-mentioned person, is or was in the opinion of the purchaser actively associated.
- 23.6 If a restriction is imposed, the purchaser must, within five (5) working days of such imposition, furnish the National Treasury, with the following information:
- (i) the name and address of the supplier and / or person restricted by the purchaser;
  - (ii) the date of commencement of the restriction
  - (iii) the period of restriction; and
  - (iv) the reasons for the restriction.

These details will be loaded in the National Treasury's central database of suppliers or persons prohibited from doing business with the public sector.

- 23.7 If a court of law convicts a person of an offence as contemplated in Schedules 12 or 13 of the Prevention and Combating of Corrupt Activities Act, No. 12 of 2004, the court may also rule that such person's name be endorsed on the Register for Tender Defaulters. When a person's name has been endorsed on the Register, the person will be prohibited from doing business with the public sector for a period not less than five years and not more than 10 years. The National Treasury is empowered to determine the period of restriction and each case will be dealt with on its own merits. According to Schedule 32 of the Act the Register must be open to the public. The Register can be perused on the National Treasury website

## **24. Anti-dumping and countervailing duties and rights**

- 24.1 When, after the date of bid, provisional payments are required, or anti-dumping or countervailing duties are imposed, or the amount of a provisional payment or anti-dumping or countervailing right is increased in respect of any dumped or subsidized import, the State is not liable for any amount so required or imposed, or for the amount of any such increase. When, after the said date, such a provisional payment is no longer required or any such anti-dumping or countervailing right is abolished, or where the amount of such provisional payment or any such right is reduced, any such favourable difference shall on demand be paid forthwith by the supplier to the purchaser or the purchaser may deduct such amounts from moneys (if any) which may otherwise be due to the supplier in regard to goods or services which he delivered or rendered, or is to deliver or render in terms of the contract or any other contract or any other amount which may be due to him.

## **25. Force Majeure**

- 25.1 Notwithstanding the provisions of GCC Clauses 22 and 23, the supplier shall not be liable for forfeiture of its performance security, damages, or termination for default if and to the extent that his delay in performance or other failure to perform his obligations under the contract is the result of an event of force majeure.
- 25.2 If a force majeure situation arises, the supplier shall promptly notify the purchaser in writing of such condition and the cause thereof. Unless otherwise directed by the purchaser in writing, the supplier shall continue to perform its obligations under the contract as far as is reasonably practical, and shall seek all reasonable alternative means for performance not prevented by the force majeure event.

## **26. Termination for insolvency**

- 26.1 The purchaser may at any time terminate the contract by giving written notice to the supplier if the supplier becomes bankrupt or otherwise insolvent. In this event, termination will be without compensation

to the supplier, provided that such termination will not prejudice or affect any right of action or remedy, which has accrued or will accrue thereafter to the purchaser.

## **27. Settlement of Disputes**

- 27.1 If any dispute or difference of any kind whatsoever arises between the purchaser and the supplier in connection with or arising out of the contract, the parties shall make every effort to resolve amicably such dispute or difference by mutual consultation.
- 27.2 If, after thirty (30) days, the parties have failed to resolve their dispute or difference by such mutual consultation, then either the purchaser or the supplier may give notice to the other party of his intention to commence with mediation. No mediation in respect of this matter may be commenced unless such notice is given to the other party.
- 27.3 Should it not be possible to settle a dispute by means of mediation, it may be settled in a South African court of law.
- 27.4 Notwithstanding any reference to mediation and/or court proceedings herein,
- (a) the parties shall continue to perform their respective obligations under the contract unless they otherwise agree; and
  - (b) the purchaser shall pay the supplier any monies due the supplier for goods delivered and / or services rendered according to the prescripts of the contract.

## **28. Limitation of Liability**

- 28.1 Except in cases of criminal negligence or wilful misconduct, and in the case of infringement pursuant to Clause 6;
- (a) the supplier shall not be liable to the purchaser, whether in contract, tort, or otherwise, for any indirect or consequential loss or damage, loss of use, loss of production, or loss of profits or interest costs, provided that this exclusion shall not apply to any obligation of the supplier to pay penalties and/or damages to the purchaser; and
  - (b) the aggregate liability of the supplier to the purchaser, whether under the contract, in tort or otherwise, shall not exceed the total contract price, provided that this limitation shall not apply to the cost of repairing or replacing defective equipment.

## **29. Governing language**

- 29.1 The contract shall be written in English. All correspondence and other documents pertaining to the contract that is exchanged by the parties shall also be written in English.

## **30. Applicable law**

- 30.1 The contract shall be interpreted in accordance with South African laws, unless otherwise specified.

## **31. Notices**

- 31.1 Every written acceptance of a bid shall be posted to the supplier concerned by registered or certified mail and any other notice to him shall be posted by ordinary mail to the address furnished in his bid or to the address notified later by him in writing and such posting shall be deemed to be proper service of such notice.
- 31.2 The time mentioned in the contract documents for performing any act after such aforesaid notice has been given, shall be reckoned from the date of posting of such notice.



### **32. Taxes and duties**

- 32.1 A foreign supplier shall be entirely responsible for all taxes, stamp duties, license fees, and other such levies imposed outside the purchaser's country.
- 32.2 A local supplier shall be entirely responsible for all taxes, duties, license fees, etc., incurred until delivery of the contracted goods to the purchaser.
- 32.3 No contract shall be concluded with any bidder whose tax matters are not in order. Prior to the award of a bid SARS must have certified that the tax matters of the preferred bidder are in order.
- 32.4 No contract shall be concluded with any bidder whose municipal rates and taxes and municipal services charges are in arrears.

### **33. Transfer of contracts**

- 33.1 The contractor shall not abandon, transfer, cede assign or sublet a contract or part thereof without the written permission of the purchaser

### **34. Amendment**

- 34.1 No agreement to amend or vary a contract or order or the conditions, stipulations or provisions thereof shall be valid and of any force unless such agreement to amend or vary is entered into in writing and signed by the contracting parties. Any waiver of the requirement that the agreement to amend or vary shall be in writing, shall also be in writing.

### **35. Prohibition of restrictive practices**

- 35.1 In terms of Schedule 4 (1) (b) (iii) of the Competition Act No. 89 of 1998, as amended, an agreement between, or concerted practice by, firms, or a decision by an association of firms, is prohibited if it is between parties in a horizontal relationship and if a bidder(s) is / are or a contractor(s) was / were involved in collusive bidding.
- 35.2 If a bidder(s) or contractor(s) based on reasonable grounds or evidence obtained by the purchaser has / have engaged in the restrictive practice referred to above, the purchaser may refer the matter to the Competition Commission for investigation and possible imposition of administrative penalties as contemplated in Schedule 59 of the Competition Act No 89 Of 1998.
- 35.3 If a bidder(s) or contractor(s) has / have been found guilty by the Competition Commission of the restrictive practice referred to above, the purchaser may, in addition and without prejudice to any other remedy provided for, invalidate the bid(s) for such item(s) offered, and / or terminate the contract in whole or part, and / or restrict the bidder(s) or contractor(s) from conducting business with the public sector for a period not exceeding ten (10) years and / or claim damages from the bidder(s) or contractor(s) concerned.

Revised: July 2010